



# Patent Law and Managing Investments in Technology

Text for a 1-hour Undergraduate-Level Patent Law Class  
v1.0 (November, 2016)

W. Michael Schuster (editor)  
Oklahoma State University

Made available under an  
Attribution 4.0 International Creative Commons License  
<https://creativecommons.org/licenses/by/4.0/>

Oklahoma State University Library ePress  
216 Edmon Low Library  
Oklahoma State University  
Stillwater, OK 74078

To learn more about the Oklahoma State University Library ePress, visit <http://epress.library.okstate.edu/>

© 2017 W. Michael Schuster and Oklahoma State University Library..

Textbook content is licensed under a [Creative Commons Attribution 4.0 International License](#). Under this license, any user of this textbook or the textbook contents herein must provide proper attribution as follows:

If you redistribute this textbook in a digital format (including but not limited to EPUB, PDF, and HTML), then you must retain on every page the following attribution: “Download for free at <http://epress.library.okstate.edu/>.”

If you redistribute this textbook in a print format, then you must include on every physical page the following attribution: “Download for free at <http://epress.library.okstate.edu/>.”

If you redistribute part of this textbook, then you must retain in every digital format page view (including but not limited to EPUB, PDF, and HTML) and on every physical printed page the following attribution: “Download for free at <http://epress.library.okstate.edu/>.”

If you use this textbook as a bibliographic reference, then you should cite it as follows:

Schuster, W.M. (Ed.). (2017). Patent law and managing investments in technology.

## Chapter 1:

### What Are Patents, Trademarks, Servicemarks, and Copyrights?

1. **What is a Patent?**
2. **What Is a Trademark or Servicemark?**
3. **What is a Copyright?**

## Chapter 2:

### Policy Behind Patent Laws

1. **Incentive to Invent**
2. **Incentive to Fully Disclose**
3. **Incentive to Keep Ideas in the Public Domain**

## Chapter 3:

### The Patent Document

1. **Who May Apply For A Patent**
2. **The Specification**
3. **Sample: U.S. Patent No. 4,941,756  
(Disposable Bag with Attached Napkin)**

## Chapter 4:

### Getting a Patent (Patent Prosecution)

1. **Patent Laws**
2. **Functions of the United States Patent and Trademark Office**
3. **What May Be Patented**
4. **What May Not Be Patented**
5. **Tests for Patentability**
6. **Prior Art**
7. **Procedures for Obtaining a Patent**
8. **Foreign Filing**
9. **Application For Patent**
  - a. **Non-Provisional Application for a Patent**
  - b. **Provisional Application for a Patent**
  - c. **Publication of Patent Application**
10. **The Duty of Candor**

## Chapter 5:

### Nature of Patent Rights and Infringement

1. **Patent Rights**
2. **Infringement of Patents**
3. **Assignments and Licenses**
4. **Recording of Assignments**
5. **Joint Ownership**

## Chapter 6:

### Litigating the Infringement of Patents

1. **Patent Litigation**
2. **Patent Misuse**
3. **Patent Trolls**

## CHAPTER 1:

# WHAT ARE PATENTS, TRADEMARKS, SERVICEMARKS, AND COPYRIGHTS?<sup>1</sup>

Some people confuse patents, copyrights, and trademarks. Although there may be similarities among these kinds of intellectual property protection, they are different and serve different purposes.

## 1. What is a Patent?

A patent for an invention is the grant of a property right to the inventor, issued by the United States Patent and Trademark Office (USPTO). Generally, the term of a new patent is 20 years from the date on which the application for the patent was filed in the United States or, in special cases, from the date an earlier, related application was filed, subject to the payment of maintenance fees. U.S. patent grants are effective only within the United States, U.S. territories, and U.S. possessions. Under certain circumstances, patent term extensions or adjustments may be available.

---

**1** Excerpt from General Information Concerning Patents, from the US Patent and Trademark Office,

<http://www.uspto.gov/sites/default/files/inventors/edu-inf/BasicPatentGuide.pdf>

This is a United States government work. It is not subject to copyright in the United States and there are no copyright restrictions on reproduction, derivative works, distribution, performance, or display of the work. See 17 U.S. Code § 105; U.S. Government Works, <https://www.usa.gov/government-works>. It is requested that in any subsequent use the United States Patent and Trademark Office (USPTO) be given appropriate acknowledgement (e.g., “Source: United States Patent and Trademark Office, www.uspto.gov”). The USPTO reserves the right to assert copyright protection internationally.

The right conferred by the patent grant is, in the language of the statute and of the grant itself, “the right to exclude others from making, using, offering for sale, or selling” the invention in the United States or “importing” the invention into the United States. What is granted is not the right to make, use, offer for sale, sell, or import, but the right to exclude others from making, using, offering for sale, selling, or importing the invention. Once a patent is issued, the patentee must enforce the patent without aid of the USPTO.

## 2. What Is a Trademark or Servicemark?

A trademark is a word, name, symbol, or device that is used in trade with goods to indicate the source of the goods and to distinguish them from the goods of others. A servicemark is the same as a trademark except that it identifies and distinguishes the source of a service rather than a product. The terms “trademark” and “mark” are commonly used to refer to both trademarks and servicemarks. As an example, the Nike Swoosh logo is a trademark identifying goods manufactured by the company. To the extent FedEx provides a service (shipping packages), anything used to identify the company is servicemark.

Trademark rights may be used to prevent others from using a confusingly similar mark (e.g., same mark in the same industry), but not to prevent others from making the same goods or from selling the same goods or services under a clearly different mark.

Trademarks used in interstate or foreign commerce may be registered with the USPTO. The registration procedure for trademarks and general information concerning trademarks can be found in a government document entitled: “Basic Facts about Trademarks”

([http://www.uspto.gov/trademarks/basics/Basic\\_Facts\\_Trademarks.jsp](http://www.uspto.gov/trademarks/basics/Basic_Facts_Trademarks.jsp))

## 3. What is a Copyright?

Copyright is a form of protection provided to the authors of “original works of authorship” including literary, dramatic, musical, artistic, and certain other intellectual works, both published and unpublished. The 1976 Copyright Act generally gives the owner of a copyright the exclusive right to reproduce the copyrighted work, to prepare derivative works, to distribute copies or phonorecords of the copyrighted work, to perform the copyrighted work publicly, and to display the copyrighted work publicly.

The copyright protects the form of expression rather than the subject matter of the writing. For example, a written description of a machine could be copyrighted, but this would only prevent others from copying the description; the copyright would not prevent others from writing a description of their own or from making and using the machine. Copyrights are registered by the Copyright Office of the Library of Congress.

# **POLICY BEHIND PATENT LAWS<sup>2</sup>**

Congress created the patent system under a constitutional mandate, stating that such a system can be enacted “To promote the Progress of Science and useful Arts.” This promotion of growth is furthered through enacting patent laws designed to provide motivation for citizens to engage in activities towards this end. Patent laws grant a limited monopoly to an inventor for a limited term in exchange for full disclosure of the invention to the public. The Supreme Court has stated that this trade between the United States and the inventor is intended to serve three basic public policy considerations: 1) encouraging invention, 2) fully disclosing inventions to the public for future use (after the patent has expired), and 3) ensuring that knowledge in the public domain remains there.

## **1. Incentive to Invent**

Invention of new technologies is a key necessity for the expansion of the knowledge available for public use. As such, it is the policy of patent laws to serve as an incentive to the inventor to create new inventions. A prime motivation to invent under the patent laws is a simple will to create an invention, patent it, and subsequently reap the financial benefits of being the exclusive agent of the product.

---

<sup>2</sup> Excerpt from Subjective Intent in the Determination of Antitrust Violations by Patent Holders, (W. Michael Schuster, South Texas Law Review, Vol. 49, No. 507, 2007) (footnotes omitted).



Technological developments may also be furthered by the knowledge that discovery and patenting of an invention can both preclude patenting of that invention by a competitor and serve as an invaluable bargaining tool during corporate negotiations. Disclosures of new technology (in accordance with procedures to gain patent protection) can serve as the basis for new innovation by subsequent inventors. New variants of products are created as parties attempt to invent around issued patents and obtain protection of their own.

Lastly, as the cost of developing new technology often runs to exorbitant sums, some economists theorize that public invention would decline considerably without governmental proprietary protection for new inventions. Such a decline would work against the public policy of furthering new technologies.

## 2. Incentive to Fully Disclose

For the public to benefit from the inventions of others, the inventor must have a reason to fully divulge their findings to the public. Patent law provides that to obtain the 20-year limited monopoly offered by statute an inventor must disclose to the public, in “full, clear, [and] concise” terminology, ample information to allow one of ordinary skill in the art to “make and use” the invention to be patented. Widespread dissemination of the disclosed material is ensured by publication of patent applications eighteen months after the earliest claimed filing date and subsequently by public access to issued patents online.

The USPTO's policy of ensuring full disclosure of a patented invention is further shown through the requirement that a patent applicant disclose preferred embodiments for practicing the claimed invention. Federal courts have recognized that “The best mode requirement creates a statutory bargained-for-exchange by which a patentee obtains the right to exclude others from practicing the claimed invention for a certain time period, and the public receives knowledge of the preferred embodiments for practicing the claimed invention.” Such a requirement removes the temptation that a patent applicant might feel to obtain a patent by disclosing information sufficient to obtain patent protection, while retaining the best method of practicing an invention for the patent applicant's exclusive use. Failure to disclose the best mode for practicing a patented invention could lead to a finding of invalidity of the patent.

Patent statutes also provide encouragement not to maintain trade secrets, which work against the public policy of seeking full disclosure of new inventions. Courts have interpreted 35 U.S.C. § 102 as denying prior inventor status to parties who maintain a new technology as a trade secret. Such holdings allow subsequent parties to independently discover a technology, obtain a patent on it, and exclude the previous inventor who held the invention as a trade secret from using the invention.

### 3. Incentive to Keep Ideas in the Public Domain

Patent law policy seeks to protect the public's right to access inventions already disclosed within the public domain. Therefore, patent statutes should attempt to ensure that once a technology has entered into the public domain the technology will remain in the grasps of the public. The public use bar serves to deny a patent on any technology that has been introduced to the public more than one year prior to the filing of a patent application. Such laws either preclude removal of technology from the public domain or limit the term of public exposure prior to enactment of patent rights.

# THE PATENT DOCUMENT

## 1. Who May Apply for a Patent<sup>3</sup>

According to the law, the inventor—or a person to whom the inventor has assigned or is under an obligation to assign the invention—may apply for a patent, with certain exceptions. If the inventor is deceased, the application may be made by their legal representatives (i.e., the administrator or executor of the estate). If the inventor is legally incapacitated, the application for patent may be made by a legal representative (e.g., guardian). If an inventor refuses to apply for a patent or cannot be found, a joint inventor may apply on behalf of the non-signing inventor.

If two or more persons make an invention jointly, they apply for a patent as joint inventors. A person who makes only a financial contribution is not a joint inventor and cannot be joined in the application as an inventor. It is possible to correct an innocent mistake in erroneously omitting an inventor or in erroneously naming a non-qualifying person as an inventor. Failing to list an inventor can potentially lead to patent invalidation.

Officers and employees of the United States Patent and Trademark Office are prohibited by law from applying for a patent or acquiring, directly or indirectly, except by inheritance or bequest, any patent or any right or interest in any patent.

---

<sup>3</sup> Excerpt (with some edits) from General Information Concerning Patents, from the US Patent and Trademark Office, <http://www.uspto.gov/sites/default/files/inventors/edu-inf/BasicPatentGuide.pdf>.

## 2. The Specification<sup>4</sup>

A patent's "specification" is all written text on a patent, other than information listed on the cover page.<sup>4</sup> A patent's specification must include a written description of the invention and of the manner and process of making and using it. The specification is required to be in such full, clear, concise, and exact terms as to enable any person skilled in the technological area to which the invention pertains (or with which the invention is most nearly connected) to make and use the same.

The specification must set forth the precise invention for which a patent is requested, in such manner as to distinguish it from other inventions and from what is already known. It must describe completely a specific embodiment of the process, machine, manufacture, composition of matter, or improvement invented, and must explain the mode of operation or principle whenever applicable. The best mode (i.e., the best way to use the invention) contemplated by the inventor for carrying out the invention must be set forth.

In the case of an improvement invention (i.e., a new improvement on a known technology), the specification must particularly point out the part or parts of the process, machine, manufacture, or composition of matter to which the improvement relates. Furthermore, the description should be confined to the specific improvement and to such parts as necessarily cooperate with it or as may be necessary to gain a complete understanding of the invention.

The title of the invention, which should be as short and specific as possible (no more than 500 characters), should appear as a heading on the first page of the specification if it does not otherwise appear at the beginning of the application. A brief abstract of the technical disclosure in the specification, including that which is new in the art to which the invention pertains, must be set forth on a separate page, preferably following the claims. The abstract should be in the form of a single paragraph of 150 words or less, under the heading "Abstract of the Disclosure."

---

<sup>4</sup> Excerpt (with some edits) from General Information Concerning Patents, from the US Patent and Trademark Office, <http://www.uspto.gov/sites/default/files/inventors/edu-inf/BasicPatentGuide.pdf>

<sup>5</sup> Note that some commenters include the claims in the specification and some don't.

A brief summary of the invention indicating its nature and substance, which may include a statement of the object of the invention, should precede the detailed description. The summary should be commensurate with the invention as claimed, and any object recited should be that of the invention as claimed.

When there are drawings, there shall be a brief description of the several views of the drawings, and the detailed description of the invention shall refer to the different views by specifying the numbers of the figures (e.g., Figure 1, Figure 2, etc.), and to the different parts by use of reference numerals (e.g., 1, 2, 3, etc.).

The specification must conclude with a claim or claims particularly pointing out and distinctly identifying the subject matter that the applicant regards as the invention. The portion of the application in which the applicant sets forth the claim or claims is an important part of the application, as these claims define the scope of the protection afforded by the patent and the manner in which questions of infringement will be judged by the courts.

More than one claim may be presented, provided they differ substantially from each other and are not unduly multiplied. These different claims describe different iterations of the invention. One or more claims may be presented in dependent form, referring back to and further limiting another claim or claims in the same application. Any dependent claim that refers back to more than one other claim is considered a “multiple dependent claim.”

As an example of dependent and independent claims, reference the sample patent in the following subsection. The claims are located at the end of the patent document (on the third page). Claim 1 is an independent claim, as it does not refer to any other claim. The fact that Claim 1 is independent is indicated by its introductory language, which does not refer to any other claim. Claims 2–4 are dependent claims, as they add limitations to the invention recited in Claim 1. These claims refer back to an earlier claim, such as Claim 2, which begins: “A bag as claimed in claim 1... .”

A multiple dependent claim refers back to more than one prior claim. It would use language such as this: “The invention claimed in claim 1 or 2, with the additional limitation... .” Multiple dependent claims shall refer to such other claims only in the alternative. A multiple dependent claim shall not serve as a basis for any other multiple dependent claim. Claims in dependent form shall be construed to include all of the limitations of the claim incorporated by reference into the dependent claim. A multiple dependent claim shall be construed to incorporate all the limitations of each of the particular claims in relation to that which it is being considered.

The claim or claims must conform to the invention as set forth in the remainder of the specification, and the terms and phrases used in the claims must find clear support or antecedent basis in the description so that the meaning of the terms may be ascertainable by reference to the description. A sample patent is presented in the following subsection.

# 3. Sample: U.S. Patent No. 4,941,756 (Disposable Bag with Attached Napkin)<sup>6</sup>

|  |  |   |
|--|--|---|
| <b>United States Patent</b> [19]   |  | [11] <b>Patent Number:</b> <b>4,941,756</b>   |
| <b>Price</b>   |  | [45] <b>Date of Patent:</b> <b>Jul. 17, 1990</b>  |
| [54] <b>DISPOSABLE BAG WITH ATTACHED NAPKIN</b>  |  | 4,542,050 9/1985 Gallant ..... 383/4 X<br>4,618,992 10/1986 La Groteria ..... 383/127 X   |
| [75] <b>Inventor:</b> John S. Price, 28 Laurretta Dr., Highland, N.Y. 12528  |  | <b>FOREIGN PATENT DOCUMENTS</b>   |
| [73] <b>Assignee:</b> John Sterling Price, Highland, N.Y.  |  | 176926 10/1906 Fed. Rep. of Germany ..... 383/71<br>290162 2/1916 Fed. Rep. of Germany ..... 383/127<br>321543 6/1920 Fed. Rep. of Germany ..... 383/127  |
| [21] <b>Appl. No.:</b> 331,831   |  | <i>Primary Examiner</i> —Stephen Marcus<br><i>Assistant Examiner</i> —Jes F. Pascua   |
| [22] <b>Filed:</b> Apr. 3, 1989  |  | [57] <b>ABSTRACT</b>  |
| [51] <b>Int. Cl.<sup>5</sup></b> ..... B65D 30/02; B65D 30/10  |  | A bag for the storage and carrying of food with an attached napkin. The bag and napkin are attached by virtue of a seam which is also intended by design to allow or indicate where separation of said bag and napkin is to occur by virtue of tearing, cutting or other manual action. |
| [52] <b>U.S. Cl.</b> ..... 383/127; 383/4; 206/233; 206/542; 206/632   |  |   |
| [58] <b>Field of Search</b> ..... 383/4, 12, 13, 70, 71, 383/127; 229/DIG. 13, 87 F; 206/233, 542, 548, 632, 831; 426/115, 124 |  |   |
| [56] <b>References Cited</b>   |  |   |
| U.S. PATENT DOCUMENTS  |  | <b>4 Claims, 1 Drawing Sheet</b>  |
| 4,484,350 11/1984 Gordon ..... 383/127 X   |  |   |

<sup>6</sup> "Subject to [presently-inapplicable] limited exceptions reflected in 37 CFR 1.71(d) & (e) and 1.84(s), the text and drawings of a patent are typically not subject to copyright restrictions." See <http://www.uspto.gov/terms-use-uspto-websites.html>

FIG. 1

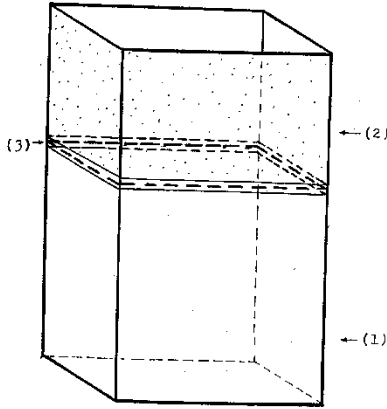
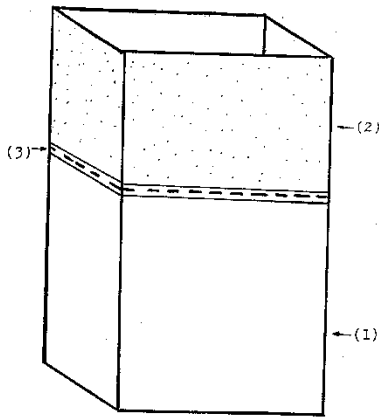

FIG. 2





**DISPOSABLE BAG WITH ATTACHED NAPKIN**

Reference Cited: U.S. Pat. No. 3,606,138

**BACKGROUND OF THE INVENTION**

This invention relates to food storage, consumption and personal hygiene.

The intent of this invention is to provide immediate and simple access to a means for personal cleanliness after the consumption of food stored within said invention, a bag with an attached napkin.

In the accompanying drawings, one may see that the attachment of said napkin requires a special provision, the introduction and novel application of a manufactured seam which serves the purposes of both joining the napkin and bag, and facilitating their separation.

**BRIEF DESCRIPTION OF DRAWINGS**

FIG. 1 is an over view of the invention, in perspective, showing the absorbent material, the seam by which it is attached, and the remaining body of the bag.

FIG. 2 is the same perspective with the hidden lines removed.

**DETAILED DESCRIPTION OF DRAWINGS**

FIG. 1 & 2 show a bag (1) with absorbent material (2) attached by virtue of a manufactured seam (3), as described in the claims of this patent.

The bag and napkin may be manufactured from paper, cloth or any suitable material(s), and the proportions shown are for convenience of drawing only.

**DETAILED DESCRIPTION OF INVENTION**

This invention resides in a bag with at least one ply of absorbent material attached to it by virtue of a manufactured seam.

The bag is so constructed that the consumer may detach the napkin from the bag by severing it along a seam running between them. After detachment the ab-

sorbent portion may be put to the usual uses of a napkin or small towel (e.g. removal of food stuff remnants, spills etc.).

It is the novel merging of two dissimilar utilitarian components and a method for using them to a singular end (the convenient and hygienic consumption of food) which is the residence of this invention.

Although the material most readily is adaptable to the production of this invention is paper, there is no intention here to exclude the use of other materials, such as cloth or plastic, or any combination of materials. The napkin consists of absorbent material, and may be of one (1) or several plies or sheets folded otherwise arranged to allow attachment to said bag.

Although the seam is more particularly referred to as adhesive, semi-adhesive, perforated or a combination thereof, this is not to preclude other methods which may secure separation. Such as potential separation line may include only a series of printed dashes or dots to indicate where the division of materials accomplished by mere tearing or cutting, or a line of stress or physical weakening between said materials.

Therefore it should be understood that the structural characteristics of the seam are not essential to the broader aspects of this invention.

I claim:

1. A bag of flexible material comprising:

an open bag mouth;  
at least one napkin of absorbent material wherein said at least one napkin is releasably connected to the bag about the open bag mouth by adhering means such that the connection defines an overlapping seam.

2. A bag as claimed in claim 1 wherein said at least one napkin is of at least one ply of absorbent material.

3. A bag as claimed in claim 1, wherein said adhering means is an adhesive.

4. A bag as claimed in claim 1 wherein said adhering means is a semi-adhesive.

\* \* \* \* \*

## CHAPTER 4:

# GETTING A PATENT (PATENT PROTECTION)

Patent prosecution is the interaction between a patent applicant (and their attorney, if applicable) and the patent office with regard to a patent application. In this process the parties interact to determine whether an application should become a patent. In the United States, the relevant patent office where prosecution occurs is the United States Patent and Trademark Office, which may also be referred to in prosecution documentation as “the USPTO,” “the Patent Office,” or simply “the Office.”

## 1. Patent Laws

The Constitution of the United States gives Congress the power to enact laws relating to patents in Article I, section 8, which reads, “Congress shall have power . . . to promote the progress of science and useful arts, by securing for limited times to authors and inventors the exclusive right to their respective writings and discoveries.” Under this power Congress has, from time to time, enacted various laws relating to patents. The patent law specifies the subject matter for which a patent may be obtained, the conditions for patentability, and establishes the USPTO as the body responsible for administering the law relating to the granting of patents. Additionally, the patent law contains various other provisions relating to patents.

## 2. Functions of the United States Patent and Trademark Office

The USPTO is an agency of the U.S. Department of Commerce. The role of the USPTO is twofold: to grant patents for the protection of inventions and to register trademarks. It serves the interests of inventors and businesses with respect to their inventions and service identifications. It also advises and assists the President of the United States, the Secretary of Commerce, the bureaus and offices of the Department of Commerce, and other government agencies in matters involving all domestic and global aspects of intellectual property. Through the preservation, classification, and dissemination of patent information, the Office promotes the industrial and technological progress of the nation and strengthens the economy.

Congress established the USPTO to issue patents on behalf of the government. The Office as a distinct bureau dates from the year 1802 when a separate official in the Department of State, who became known as “Superintendent of Patents,” was placed in charge of patents. The revision of the patent laws enacted in 1836 reorganized the Patent Office and designated the official in charge as “Commissioner of Patents.” The Patent Office remained in the Department of State until 1849 when it was transferred to the Department of Interior. In 1925 it was transferred to the Department of Commerce, where it remains today. The name of the Patent Office was changed to the Patent and Trademark Office in 1975 and changed to the United States Patent and Trademark Office in 2000.

---

<sup>7</sup> This subsection was adopted from <http://www.uspto.gov/web/offices/pac/doc/general//> and <http://www.uspto.gov/patents-getting-started/general-information-concerning-patents>

In discharging its patent-related duties, the USPTO examines applications and grants patents on inventions when applicants are entitled to them; it publishes and disseminates patent information, records assignments of patents, maintains search files of U.S. and foreign patents, and maintains a search room for public use in examining issued patents and records. The Office supplies copies of patents and official records to the public. It provides training to practitioners as to the requirements of the patent statutes and regulations, and it publishes the Manual of Patent Examining Procedure (MPEP) to elucidate these. By protecting intellectual endeavors and encouraging technological progress, the USPTO seeks to preserve the United States' technological edge. The USPTO also disseminates patent and trademark information that promotes an understanding of intellectual property protection and facilitates the development and sharing of new technologies worldwide.

The work of examining applications for patents is divided among a number of examining technology centers (TCs), each TC having jurisdiction over certain assigned fields of technology. Every TC is headed by a group directors and staffed by examiners and support staff. The examiners review applications for patents and determine whether patents should be granted. If the examiners refuse to grant a patent, an appeal can be made to the Patent Trial and Appeal Board and a review by the Director of the USPTO may be requested on other matters by petition. In addition to the examining TCs, other offices perform various services, such as receiving and distributing mail, receiving new applications, handling sales of printed copies of patents, making copies of records, inspecting drawings, and recording assignments.

At present, the USPTO has over 12,000 employees, of whom about three quarters are examiners and others with technical and legal training. Patent applications are received at a rate of over 500,000 per year.

### 3. What May Be Patented<sup>8</sup>

The patent law says that “any new and useful process, machine, manufacture, or composition of matter, or any new and useful improvement thereof” may be patented.

A “process” is a “process, art or method, and includes a new use of a known process, machine, manufacture, composition of matter, or material.” For example, a process for making rolled steel qualifies as a patentable process under the statute.

A “machine” is a particular apparatus for achieving a certain result or carrying out a distinct process—lathes, printing presses, motors, and the cotton gin are all examples of the hundreds of thousands of machines that have received US patents since the first Patent Act in 1790.

A “manufacture” is an article or a product, such as a television, an automobile, a telephone, or a lightbulb.

A “composition of matter” is a new arrangement of elements so that the resulting compound, such as a metal alloy, is not found in nature.

In 1980, the Supreme Court said that even living organisms—in particular, a new “genetically engineered” bacterium that could “eat” oil spills—could be patented. This decision has spawned innovation: a variety of small biotechnology firms have attracted venture capitalists and other investors.

There are still other categories of patentable subjects. An “improvement” is an alteration of a process, machine, manufacture, or composition of matter that satisfies the tests for patentability. New varieties of cultivated or hybridized plants are also patentable, as are genetically modified strains of soybean, corn, or other crops.

---

<sup>8</sup> Adapted from Government Regulation and the Legal Environment of Business (v. 1.0, Saylor Academy, 2012—text made available under a Creative Commons Attribution-NonCommercial-ShareAlike 3.0 License)  
[https://saylordotorg.github.io/text\\_government-regulation-and-the-legal-environment-of-business/s16-01-patents.html](https://saylordotorg.github.io/text_government-regulation-and-the-legal-environment-of-business/s16-01-patents.html)

## 4. What May Not Be Patented<sup>9</sup>

Many things can be patented, but not 1) the laws of nature, 2) natural phenomena, and 3) abstract ideas.

One frequently asked question is whether patents can be issued for computer software. The USPTO was reluctant to do so at first, based on the notion that computer programs were not “novel”—the software program either incorporated automation of manual processes or used mathematical equations (which were not patentable). But, in 1998, the Supreme Court held that patents could be obtained for a process that incorporated a computer program if the process itself was patentable.

A business process can also be patentable, as the US Court of Appeals for the Federal Circuit ruled in 1998 in *State Street Bank and Trust v. Signature Financial Group*. In that case, Signature Financial had a patent for a computerized accounting system that determined share prices through a series of mathematical calculations that would help manage mutual funds. State Street sued to challenge that patent. Signature argued that its model and process was protected, and the court of appeals upheld it as a “practical application of a mathematical, algorithm, formula, or calculation” because it produces a “useful, concrete and tangible result.” Since State Street, many other firms have applied for business process patents.

It is notable that, while software and business method patents are viable, many critics argue that the USPTO should not issue these patents. Additionally, courts have recently interpreted relevant precedent to narrow the range of software and business methods that are patentable.

---

<sup>9</sup> Adapted from *Government Regulation and the Legal Environment of Business* (v. 1.0, Saylor Academy, 2012—text made available under a Creative Commons Attribution-NonCommercial-ShareAlike 3.0 License)  
[https://saylordotorg.github.io/text\\_government-regulation-and-the-legal-environment-of-business/s16-01-patents.html](https://saylordotorg.github.io/text_government-regulation-and-the-legal-environment-of-business/s16-01-patents.html)

## 5. Tests for Patentability<sup>10</sup>

Just because an invention falls within one of the categories of patentable subjects mentioned above, it is not necessarily patentable. The Patent Act and judicial precedent have established certain tests that must be met before a patent is granted. To approve a patent application, the USPTO will require that the invention, discovery, or process be novel, useful, and nonobvious in light of current technology.

Novelty is a patentability requirement. An invention is not new and therefore not patentable if it was known to the public before the date of filing of the patent application, or before its date of priority if the priority of an earlier patent application is claimed. The purpose of the novelty requirement is to prevent previously known “inventions” from being patented again. All previously known inventions are described in the “prior art,” which constitutes all information that might be relevant to a patent's claims of originality as made available to the public in any form before a given date. If an invention has been described in the prior art, a patent on that invention is not valid and should not be granted. Prior art is further discussed in the following subsection.

A patent grants an inventor a legally enforceable monopoly over their invention. This means that others can be legally restrained from exploiting the invention. It is not the intention of the patent system to deny anyone what they have been free to do before someone claims an invention. For example, one cannot patent the wheel, as that would exclude others from manufacturing wheels despite having previously been free to do so. Because the legal test for patentability is that the invention must be something new (i.e. it must possess "novelty") and the invention of the wheel is not new, the wheel is considered part of the prior art.

---

**10** Adapted from Government Regulation and the Legal Environment of Business (v. 1.0, Saylor Academy, 2012—text made available under a Creative Commons Attribution-NonCommercial-ShareAlike 3.0 License)  
[https://saylordotorg.github.io/text\\_government-regulation-and-the-legal-environment-of-business/s16-01-patents.html](https://saylordotorg.github.io/text_government-regulation-and-the-legal-environment-of-business/s16-01-patents.html) and [https://en.wikipedia.org/wiki/Novelty\\_\(patent\)](https://en.wikipedia.org/wiki/Novelty_(patent)) and [https://en.wikipedia.org/wiki/Prior\\_art](https://en.wikipedia.org/wiki/Prior_art)

Another significant test of patentability is that of obviousness. The law says that no invention may be patented “if the differences between the claimed invention and the prior art are such that the claimed invention as a whole would have been obvious before the effective filing date of the claimed invention to a person having ordinary skill in the art to which the claimed invention pertains.” This provision of the law has produced innumerable court cases, especially over improvement patents, when those who wish to use an invention on which a patent has been issued have refused to pay royalties on the grounds that the invention was obvious to anyone who looked.

## 6. Prior Art<sup>11</sup>

“Prior art” is the information that is publicly available as of a given date. Prior art available before a specific date (such as the filing date of a patent) may affect whether a patent will be granted.

35 U.S.C. 102(a) defines the prior art that will preclude the grant of a patent on a claimed invention unless an exception in 35 U.S.C. 102(b) is applicable. Specifically, 35 U.S.C. 102(a) provides (in paraphrase) that:

[a] person can get a patent unless—

(1) the invention was patented, described in a printed publication, or in public use, on sale, or otherwise available to the public before the effective filing date of the patent application; or

(2) the claimed invention was described in a patent or in a published patent application filed by another inventor before the effective filing date of the patent application.

The categories of prior art are set forth in 102(a). These documents and activities are used to determine whether a claimed invention is novel or nonobvious. The documents upon which a prior art rejection under 35 U.S.C. 102(a)(1) may be based are an issued patent, a published patent application, and a non-patent publication. The documents upon which a prior art rejection under 35 U.S.C. 102(a)(2) may be based are U.S. patent documents only. Evidence that the claimed invention was in public use, on sale, or otherwise available to the public may also form the basis for a prior art rejection under 35 U.S.C. 102(a)(1).

---

<sup>11</sup> This Section contains edited material from <http://www.uspto.gov/web/offices/pac/mpep/s2152.html>, which is not subject to copyright in the United States.



35 U.S.C. 102(b) sets out exceptions to 35 U.S.C. 102(a), in that prior art that otherwise would be included in 35 U.S.C. 102(a) shall not be prior art if it falls within an exception under 35 U.S.C. 102(b). Exceptions to the categories of prior art defined in 35 U.S.C. 102(a)(1) are provided in 35 U.S.C. 102(b)(1). Specifically, 35 U.S.C. 102(b)(1) states (with some edits) that “[a] disclosure made 1 year or less before the effective filing date of a claimed invention shall not be prior art to the claimed invention under subsection (a)(1) if—

(A) the disclosure was made by the inventor or a joint inventor or by another who obtained the subject matter disclosed directly or indirectly from the inventor or a joint inventor; or

(B) the subject matter disclosed had, before such disclosure, been publicly disclosed by the inventor or a joint inventor or another who obtained the subject matter disclosed directly or indirectly from the inventor or a joint inventor.”

## 7. Procedures for Obtaining a Patent<sup>12</sup>

An inventor does not obtain a patent automatically; obtaining a patent is an expensive and time-consuming process, and the inventor will need the services of a patent attorney. The attorney will help develop the required specification, a description of the invention that gives enough detail so that one skilled in the art will be able to make and use the invention. After receiving an application, a USPTO examiner will search the records and accept or reject the claim. Usually, the attorney will negotiate with the examiner and will rewrite and refine the application until it is accepted. A rejection may be appealed, first to the USPTO’s Patent Trial and Appeal Board and then, if that fails, to the federal district court in the District of Columbia or to the US Court of Appeals for the Federal Circuit.

---

**12** Adapted from Government Regulation and the Legal Environment of Business (v. 1.0, Saylor Academy, 2012—text made available under a Creative Commons Attribution-NonCommercial-ShareAlike 3.0 License), [https://saylordotorg.github.io/text\\_government-regulation-and-the-legal-environment-of-business/s16-01-patents.html](https://saylordotorg.github.io/text_government-regulation-and-the-legal-environment-of-business/s16-01-patents.html)

Once a patent application has been filed, the inventor (or a company to which the inventor has assigned the invention) may put the words “patent pending” on the invention. These words have no legal effect. Anyone is free to make the invention as long as the patent has not yet been issued. But the words “patent pending” do put others on notice that a patent has been applied for. Once the patent has been granted, infringers may be sued even if the infringer has made the product and offered it for sale before the patent was granted.

## 8. Foreign Filing<sup>13</sup>

In today’s global market, obtaining a US patent is important but is not usually sufficient protection. The inventor may need to secure patent protection in other countries as well. Under the Paris Convention for the Protection of Industrial Property (1883), parties in one country can file for patent or trademark protection in any of the other member countries. As of 2011, 172 countries had adopted this agreement.

The World Trade Organization’s Agreement on Trade-Related Aspects of Intellectual Property Rights (TRIPS) established standards for protecting intellectual property rights (patents, trademarks, and copyrights) and provides that each member nation must have laws that protect intellectual property rights with effective access to judicial systems for pursuing civil and criminal penalties for violations of such rights.

---

<sup>13</sup> This subsection was adopted from <http://www.uspto.gov/web/offices/pac/doc/general/> and <http://www.uspto.gov/patents-getting-started/general-information-concerning-patents>

## 9. Application for Patent<sup>14</sup>

### a. Non-Provisional Application for a Patent

A non-provisional application for a patent is made to the Director of the United States Patent and Trademark Office and includes:

- (1) A written document which comprises a specification (description and claims);
- (2) Drawings (when necessary);
- (3) An oath or declaration asserting that, to the best of their knowledge, the listed inventors are correct and promising to disclose any information relevant to the patent application; and
- (4) Filing, search, and examination fees.

The specification must conclude with a claim or claims particularly pointing out and distinctly claiming the subject matter that the applicant regards as the invention. The portion of the application in which the applicant sets forth the claim or claims is an important part of the application, as it is the claims that define the scope of the protection afforded by the patent.

More than one claim may be presented provided they differ from each other. Claims may be presented in independent form (i.e., the claim stands by itself) or in dependent form, referring back to and further limiting another claim or claims in the same application. Any dependent claim that refers back to more than one other claim is considered a “multiple dependent claim.”

---

<sup>14</sup> This subsection was adopted from <http://www.uspto.gov/web/offices/pac/doc/general/> and <http://www.uspto.gov/patents-getting-started/general-information-concerning-patents>

The patent application is not forwarded for examination until all required parts— complying with the rules related thereto—are received. If any application is filed without all the required parts for obtaining a filing date (resulting in an incomplete or defective application), the applicant will be notified of the deficiencies and given a time period to complete the application filing. Additionally, a surcharge may be required. If the omission is not corrected within the specified time period, the application will be returned or otherwise disposed of; the filing fee—if submitted—will be refunded less a handling fee as set forth in the fee schedule.

The filing date of an application for patent is the date on which a specification (including at least one claim) and any drawings necessary to understand the subject matter sought to be patented are received by the USPTO, or the date on which the last part completing the application is received in the case of a previously incomplete or defective application.

Fees for filing, searching, examining, issuing, appealing, and maintaining patent applications and patents are reduced by 50 percent for any small entity that qualifies for reduced fees, and are reduced by 75% for any micro entity that files a certification evidencing the legal requirements to claim micro entity status. Generally, small entities are individual inventors, companies with less than 500 employees, or non-profits. A micro entity is a party that meets the requirements for a small entity, has not been named as an inventor on more than four patent applications, and does not have a gross income more than three times the median household income of the previous year. A list of fees and charges associated with getting a patent can be found at: <http://www.uspto.gov/learning-and-resources/fees-and-payment/uspto-fee-schedule> .

#### b. Provisional Application for a Patent

Since June 8, 1995, the USPTO has offered inventors the option of filing a provisional application for patent, which was designed to provide a lower-cost first patent filing in the United States. Claims and oath or declaration are not required for a provisional application. A provisional application provides the means to establish an early effective filing date in a patent application and permits the term “Patent Pending” to be applied in connection with the invention.

The filing date of a provisional application is the date on which a written description of the invention, and drawings if necessary, are received by the USPTO, after which time the applicant has up to 12 months to file a non-provisional application for patent as described above. The claimed subject matter in the later filed non-provisional application is entitled to the benefit of the filing date of the provisional application if it has support in the provisional application.

Provisional applications are not examined on their merits. A provisional application will become abandoned 12 months from its filing date.

### c. Publication of Patent Applications

Publication of patent applications is required by the American Inventors Protection Act of 1999 for most patent applications. Publication occurs after the expiration of an 18-month period following the earliest effective filing date or priority date claimed by an application. Following publication, the application for patent is no longer held in confidence by the Office, and any member of the public may request access to the entire file history of the application.

As a result of publication, an applicant may assert provisional rights. These rights provide a patentee with the opportunity to obtain a reasonable royalty from a third party that infringes on a published application claim provided actual notice is given to the third party by the applicant, and the dispute issues from an application with a substantially identical claim. Thus, damages for pre-patent grant infringement by another are available.

## 10. The Duty of Candor

The duty of candor and good faith in dealing with the USPTO is an obligation for each individual associated with the filing and prosecution of a patent application. Parties associated with a patent application include the inventor(s), attorney or agents responsible for the prosecution, and any other party who is “substantively involved in the preparation or prosecution of the application and who is associated with the inventor, with the assignee or with anyone to whom there is an obligation to assign the application.” This obligation instills a duty to disclose to the patent examiner all information the applicant knows to be material to patentability. An applicant is under no affirmative obligation to conduct a prior art search in order to seek out any potential material information, but the applicant may not keep themselves in a state of cultivated ignorance in order to avoid knowing that material information exists and has not been submitted to the examiner. Information is considered material to patentability if it establishes, by itself or in combination with other information, a case of unpatentability of any claim, or is inconsistent with any position asserted by the applicant in arguing against a claim of unpatentability or arguing for a claim of patentability. Information that would determine a claim unpatentable by a preponderance of the evidence establishes a case of unpatentability. The duty of candor extends throughout the lifetime of the patent application.

The duty of candor serves the public interest by ensuring the most effective patent examination occurs at the time an application is being examined, and by making sure that the patent examiner is aware of all information material to the patentability of the present application. The requirement of disclosure of material information by the applicant is necessitated by the fact that the USPTO lacks proper means for fully investigating patent claims.

The duty of candor furthers the issuance of patents that are new and useful, as most patent applicants will presumptively choose to submit material information in order to strengthen their patent and avoid the risks of a potentially disastrous incorrect judgment regarding the materiality of particular information. Further, applicants regularly choose to submit information of questionable materiality in order to ensure that they avoid suspicion of attempting to deceive the USPTO.

# **NATURE OF PATENT RIGHTS AND INFRINGEMENT<sup>15</sup>**

## **1. PATENT RIGHTS**

Patents are issued in the name of the United States under the seal of the United States Patent and Trademark Office. The patent contains a grant to the patentee, and a printed copy of the specification and drawing is annexed to the patent and forms a part of it. The grant confers “the right to exclude others from making, using, offering for sale, or selling the invention throughout the United States or importing the invention into the United States” and its territories and possessions. The term of the patent is generally 20 years from the date on which the application for the patent was filed in the United States or, if the application claims priority to an earlier filed application, from the date the earliest such application was filed and subject to the payment of maintenance fees as provided by law.

---

**15** Adopted from <https://www.uspto.gov/patents-getting-started/general-information-concerning-patents>

A maintenance fee is due 3.5, 7.5 and 11.5 years after the original grant for all patents issuing from the applications filed on and after December 12, 1980. The maintenance fee must be paid at the stipulated times to maintain the patent in force. After the patent has expired anyone may make, use, offer for sale, sell, or import the invention without permission of the patentee, provided that matter covered by other unexpired patents is not used. The terms may be extended for certain pharmaceuticals and for certain circumstances as provided by law.

The exact nature of the rights conferred must be carefully distinguished, and the key is in the words “right to exclude” in the phrase just quoted. The patent does not grant the right to make, use, offer for sale, sell, or import the invention. Instead, the patent grants the exclusive nature of the right. Any person is ordinarily free to make, use, offer for sale, sell, or import anything he or she pleases, and a grant from the government is not necessary. The patent only grants the right to exclude others from making, using, offering for sale, selling, or importing the invention. Since the patent does not grant the right to make, use, offer for sale, sell, or import the invention, the patentee’s own right to do so is dependent upon the rights of others and whatever general laws might be applicable. A patentee, merely because he or she has received a patent for an invention, is not thereby authorized to make, use, offer for sale, sell, or import the invention if doing so would violate any law.

An inventor of a new automobile who has obtained a patent thereon would not be entitled to use the patented automobile in violation of the laws of a state requiring a license, nor may a patentee sell an article—the sale of which may be forbidden by a law—merely because a patent has been obtained.

Neither may a patentee make, use, offer for sale, sell, or import his or her own invention if doing so would infringe the prior rights of others. A patentee may not violate the federal antitrust laws, such as by resale price agreements or entering into combination in restraints of trade, or the pure food and drug laws by virtue of having a patent. Ordinarily there is nothing that prohibits a patentee from making, using, offering for sale, selling, or importing his or her own invention, unless he or she thereby infringes another’s patent that is still in force. For example, a patent for an improvement of an original device already patented would be subject to the patent on the device.



## 2. Infringement of Patents

Infringement of a patent consists of the unauthorized making, using, offering for sale, or selling any patented invention within the United States or U.S. Territories, or importing into the United States of any patented invention during the term of the patent. If a patent is infringed, the patentee may sue for relief in the appropriate federal court. The patentee may ask the court for an injunction to prevent the continuation of the infringement and may also ask the court for an award of damages because of the infringement.

In such an infringement suit, the defendant may challenge the validity of the patent, which is then decided by the court. If the defendant successfully establishes that the asserted patent(s) is invalid (e.g., at the time it was filed, the claimed invention was not novel or was obvious), the defendant will win the case, as you cannot infringe an invalid patent. The defendant may also argue that what they are doing does not constitute infringement. Infringement is determined by the language of the claims of the patent and, if what the defendant is making does not fall within the language of any of the claims of the patent, there is no literal infringement.

Suits for infringement of patents follow the rules of procedure of the federal courts. From the decision of the district court, there is an appeal to the Court of Appeals for the Federal Circuit. The Supreme Court may thereafter take a case by writ of certiorari. If the United States Government infringes a patent, the patentee has a remedy for damages in the United States Court of Federal Claims. The government may use any patented invention without permission of the patentee, but the patentee is entitled to obtain compensation for the use by or for the government.

The Patent Office has no jurisdiction over questions relating to infringement of patents. That authority lies solely with the courts. In examining applications for patent, the Patent Office makes no determination as to whether the invention sought to be patented infringes any prior patent. An improvement invention may be patentable, but it might infringe a prior unexpired patent for the invention improved upon, if there is one.

### 3. Assignments and Licenses

A patent is personal property and may be sold to others or mortgaged; it may be bequeathed by a will; and it may pass to the heirs of a deceased patentee. The patent law provides for the transfer or sale of a patent, or of an application for patent, by an instrument in writing. Such an instrument is referred to as an “assignment” and may transfer the entire interest in the patent. The assignee, when the patent is assigned to him or her, becomes the owner of the patent and has the same rights the original patentee had.

The statute also provides for the assignment of a part interest, that is, a half interest, a fourth interest, etc., in a patent. There may also be a grant that conveys the same character of interest as an assignment but only for a particularly specified part of the United States. A mortgage of patent property passes ownership thereof to the mortgagee or lender until the mortgage has been satisfied and a retransfer from the mortgagee back to the mortgagor (i.e., the borrower) is made. A conditional assignment also passes ownership of the patent and is regarded as absolute until canceled by the parties or by the decree of a competent court.

### 4. Recording of Assignments

The Office records assignments, grants, and similar instruments sent to it for recording, and the recording serves as notice. If an assignment, grant, or conveyance of a patent or an interest in a patent (or an application for patent) is not recorded in the Office within three months from its date, it is void against a subsequent purchaser for a valuable consideration without notice, unless it is recorded prior to the subsequent purchase.

An instrument relating to a patent should identify the patent by number and date; the name of the inventor and title of the invention as stated in the patent should also be given. An instrument relating to an application should identify the application by its application number and date of filing, the name of the inventor, and title of the invention as stated in the application should also be given. Sometimes an assignment of an application is executed at the same time that the application is prepared and before it has been filed in the Office.

Such assignment should adequately identify the application by its date of execution, inventor, and title of the invention so that there can be no mistake as to the application intended. If an application has been assigned and the assignment has been recorded or filed for recordation, the patent will be issued to the assignee as owner so long as the name of the assignee is provided when the issue fee is paid and the patent is requested to be issued to the assignee. If the assignment is of a part interest only, the patent will be issued to the inventor and assignee as joint owners.

## 5. Joint Ownership

Patents may be owned jointly by two or more persons as in the case of a patent granted to joint inventors, or in the case of the assignment of a part interest in a patent. Any joint owner of a patent, no matter how small the part interest, may make, use, offer for sale, sell, and import the invention for his or her own profit provided they do not infringe another's patent rights, and they may do so without regard to the other owners. Additionally, joint owners may sell their interest or any part of it, or grant licenses to others, without regard to the other joint owner, unless the joint owners have a binding contract that forbids them from doing so. It is accordingly dangerous to assign a part interest without a definite agreement between the parties as to the extent of their respective rights and their obligations to each other.

The owner(s) of a patent may grant licenses to others. Since the patentee has the right to exclude others from making, using, offering for sale, selling, or importing the invention, no one else may do any of these things without his or her permission.

A patent license agreement is in essence nothing more than a promise by the licensor not to sue the licensee. No particular form of license is required; a license is a contract and may include whatever provisions the parties agree upon, including the payment of royalties, etc.

The drawing up of a license agreement (as well as assignments) is within the field of an attorney at law. Such an attorney should be familiar with patent matters as well. A few states have prescribed certain formalities to be observed in connection with the sale of patent rights.

## CHAPTER 6:

# LITIGATING THE INFRINGEMENT OF PATENTS

### 1. PATENT LITIGATION

Suits for patent infringement can arise in three ways: 1) the patent holder may seek damages and an injunction against the infringer in federal court, requesting damages for royalties and lost profits as well; 2) even before being sued, the accused party may take the patent holder to court under the federal Declaratory Judgment Act, seeking a court declaration that the patent is invalid; 3) the patent holder may sue a licensee for royalties claimed to be due, and the licensee may counterclaim that the patent is invalid. Such a suit, if begun in state court, may be removed to federal court.

---

**16** Adapted from Government Regulation and the Legal Environment of Business (v. 1.0, Saylor Academy, 2012—text made available under a Creative Commons Attribution-NonCommercial-ShareAlike 3.0 License) [https://saylordotorg.github.io/text\\_government-regulation-and-the-legal-environment-of-business/s16-01-patents.html](https://saylordotorg.github.io/text_government-regulation-and-the-legal-environment-of-business/s16-01-patents.html).

In a federal patent infringement lawsuit, the court may grant the winning party reimbursement for attorneys' fees and costs. If the infringement is adjudged to be intentional, the court can triple the amount of damages awarded. Prior to 2006, courts were typically granting permanent injunctions to prevent future infringement. In 2006, the Supreme Court ruled that patent holders are not automatically entitled to a permanent injunction against infringement during the life of the patent. Courts have the discretion to determine whether justice requires a permanent injunction, and they may conclude that the public interest and equitable principles may be better satisfied with compensatory damages alone.

Proving infringement can be a difficult task. Many companies employ engineers to “design around” a patent product—that is, to seek ways to alter the product to such an extent that the substitute product no longer shares the invented elements safeguarded by the patent. However, infringing products, processes, or machines need not be identical; as the Supreme Court said in 1929, “one device is an infringement of another...if two devices do the same work in substantially the same way, and accomplish substantially the same result...even though they differ in name, form, or shape.” This is known as the “doctrine of equivalents.” In an infringement suit, the court must choose between these two extremes: legitimate “design around” and infringement through an equivalent product.

An infringement suit can often be dangerous because the defendant will almost always assert in their answer that the patent is invalid. The plaintiff patent holder thus runs the risk that his or her entire patent will be taken away if the court agrees. In ruling on validity, the court may consider all tests for patentability, such as novelty and obviousness, and rule on these independently of the conclusions drawn by the Patent Office.

---

**17** Adapted from Government Regulation and the Legal Environment of Business (v. 1.0, Saylor Academy, 2012—text made available under a Creative Commons Attribution-NonCommercial-ShareAlike 3.0 License) [https://saylordotorg.github.io/text\\_government-regulation-and-the-legal-environment-of-business/s16-01-patents.html](https://saylordotorg.github.io/text_government-regulation-and-the-legal-environment-of-business/s16-01-patents.html).

## 2. Patent Misuse

Although a patent is a monopoly granted to the inventor or their assignee or licensee, the monopoly power is legally limited. An owner who misuses the patent may find that they will lose an infringement suit. One common form of misuse is to tie the patented good to some unpatented one—for example, a patented movie projector that will not be sold unless the buyer agrees to rent films supplied only by the manufacturer of the movie projector, or a copier manufacturer that requires buyers to purchase plain paper from it. Another form of patent misuse is a provision in the licensing agreement prohibiting the manufacturer from also making competing products. Although the courts have held against several other types of misuse, the general principle is that the owner may not use their patent to restrain trade in unpatented goods.

## 3. Patent Trolls<sup>18</sup>

Patent owners whose primary source of income is collecting money from purported infringers of their patents go by many names: patent assertion entities, non-practicing entities, patent monetization entities, or (more commonly) patent trolls. While specific definitions of these terms vary, the shared attribute among them is that each utilizes a patent licensing model to make money through direct patent licensing or infringement litigation. For ease of presentation, this text uses “patent trolls” (or “trolls”) as shorthand for this group of business models.

Though the practices of individual patent trolls vary, the generalized business model begins by obtaining patents arguably practiced by working businesses. Once the patents are purchased, demand letters offering to sell a license to the patents are sent to anyone who arguably uses the claimed technology. The patent troll will then file an infringement lawsuit against some subset of those receiving demand letters and aggressively seek to settle before trial.

---

**18** The below section is adapted from W. Michael Schuster’s article, *Invalidity Assertion Entities and Inter Partes Review: Rent Seeking as a Tool to Discourage Patent Trolls* (51 Wake Forest L. Rev. 1163 (2016)).

It is notable that the literature recognizes several variations on this theme, some of which deviate from the above generalization. One sub-group targets a small number of very large alleged infringers, hoping that their patent will be deemed valid and infringed, leading to a single large payday. A second type—“bottom feeder trolls”—target a very large number of purported infringers, with hopes of obtaining a settlement below the target’s cost to defend the allegations in court. The patent’s validity is not important to bottom feeders, as they hope to settle prior to a validity challenge. Patent aggregators are the third variation; they amass huge numbers of patents in a technological area and offer licenses to use the entire group.

Trolls now own a large number of the most-litigated patents and file most of the infringement lawsuits in the United States. The significant majority of these cases end in settlement, commonly priced below the defendant’s expected cost of litigation (per the “bottom feeder” troll’s modus operandi). When patent trolls go to trial, they usually lose, with one study finding that they win only 9.2% of cases that reach a decision on the merits (including default judgments). The expense of pursuing a likely-losing trial is however, a necessary one. A willingness to go to trial furthers a troll’s future bargaining power by establishing a reputation to force defendants to incur the expense of a full trial should they prove recalcitrant.

Critics of this business model allege that it is a “tax on innovation,” which undermines patent law’s goal of encouraging invention. Several studies argue that the prospect of troll-litigation encourages corporations to rationally divert funds from research and development activities. Other commenters note that venture capitalists shy away from investments because of troll entanglements, including one study that estimated \$21.7 billion more would be invested were it not for trolls. Similarly, a survey of 200 venture capitalists found that every participant “might refrain from investing” in a company with a patent asserted against it.

For more information on patent trolls, see <http://www.ipwatchdog.com/patent-trolls/> .